



Scan for full manual

OSP-MM1, OSP-SM10 Quick Start Guide

This guide helps you install and use your OSP-MM1 / OSP-SM10 for the first time.

Go to www.kramerav.com/downloads/OSP-MM1 or www.kramerav.com/downloads/OSP-SM10 to download the latest user manual and check if firmware upgrades are available.

Step 1: Check what's in the box

- ✓ OSP-MM1 Optical MM 850nm 10G SFP+ Transceiver or OSP-SM10 Optical SM 1310nm 10G SFP+ Transceiver
- ✓ 1 Quick start guide

Step 2: Get to know your OSP-MM1 / OSP-SM10

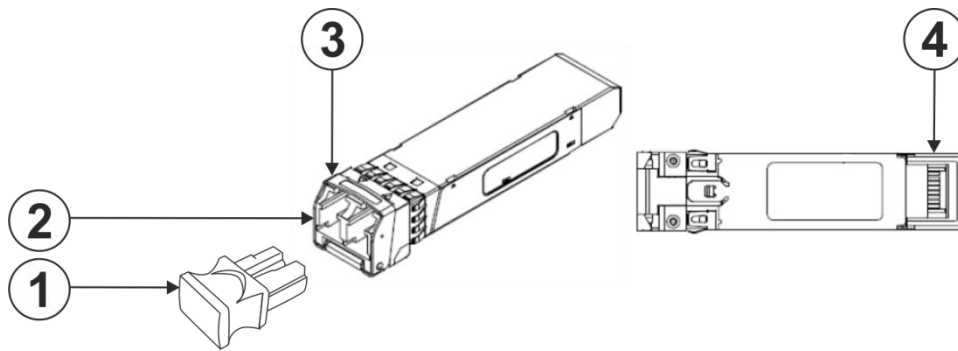

#	Feature	Function
1	Cap	Protects the LC connectors from dust. Note: When transporting or storing an unconnected device, keep the cap on to protect against dust.
2	LC Connectors	For connecting fiber optic cables. Covered with protective cap when not in use.
3	Bail (Handle)	Pull down the handle for easy removal of the transceiver from the optical device.
4	SFP+ Device Interface	Connects to the optical device SFP+ port.

Step 3: Safety Instructions

Warning: Class 1 Laser Product:

- Invisible laser radiation present.
- Avoid long-term viewing of laser.
- Avoid the use of magnifying viewing aids or instruments (such as binoculars, telescopes, microscopes and magnifying lenses, but not spectacles or contact lenses).
- Avoid placing optical devices in the emitted beam that could cause the concentration of the laser radiation to be increased.

Step 4: Operation and Installation Warnings

- **OSP-MM1** and **OSP-SM10** are designed to be used with LC(PC) and LC(UPC) connectors. Using an LC(APC) connector causes poor performance and can damage the connector.
- Always inspect and clean the connectors before you make a connection.
- Always use the connector housing to plug or unplug a fiber.
- Never touch the end face of the fiber connectors.

Step 5: Install the OSP-MM1 / OSP-SM10

To install the OSP SFP+ transceiver:

1. Make sure the bail is pushed up, in the closed position.
2. Insert the OSP SFP+ transceiver into the relevant optical device SFP+ slot and push it in until it clicks.
3. Remove the protective cap and store it in a safe place for future use.

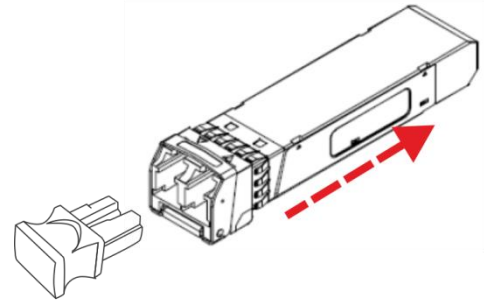

To remove the OSP SFP+ transceiver:

1. Pull the bail down to release the transceiver unit.
2. Pull the transceiver unit out by the bail from the optical device SFP+ slot.
3. If needed, put the protective cap back on.

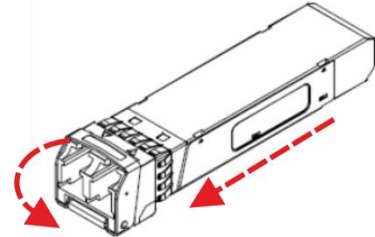

For optimum range and performance use the recommended Kramer cables available at www.kramerav.com/product/OSP-MM1 or www.kramerav.com/product/OSP-SM10 Using third-party cables may cause damage!

Step 6: Technical Specifications

	OSP-MM1	OSP-SM10
Transceiver Wavelength:	850nm	1310nm
Optical Fiber Line Type:	Multi-mode	Single-mode
Optical Transmitter Type:	VCSEL	DFB
Typical Optical Transmission Power:	-2.5dBm	-2.5dBm
Typical Optical Maximum Receiver Sensitivity:	-11.1dBm	-14.4dBm
Typical Optical Maximum Loss Budget:	8.6dB	11.9dB
Ports:	2 strand fiber optic LC (PC/UPC) connector for reception and transmission SFP+ compliant pluggable interface Note: Do not use with LC(APC) connectors.	
Data Rate:	10Gbps	
Standards Compliance:	IEEE 802.3ae, SFF-8431	
Laser Safety Compliance:	Laser Class I	
Regulatory Certifications:	FDA CDRH 21 CFR 1040 and Laser Notice No. 50 UL and CUL EN60950-2:2007 RoHS6 Directive 2002/95/EC EMC EN 55022:2006+A1:2007; EN 55024:1998+A1+A2:2003	
Operating Temperature:	0° to 70°C	
Storage Temperature:	-40° to 85°C	
Humidity:	5% to 95% RH	
Power Consumption:	1W	
Product Dimensions:	1.33cm x 5.7cm x 0.85cm (0.52" x 2.2" x 0.33") W, D, H	
Product Weight:	0.018kg (0.04lbs)	
Shipping Dimensions:	4.1cm x 12.6cm x 8.4cm (1.6" x 5" x 3.3") H, W, D	
Shipping Weight:	0.06kg (0.13lbs)	
Specifications are subject to change without notice at www.kramerav.com		